

CAPITAL MARKETS DAY

JUNE 14-15, 2018 | PARIS CAMPUS, FRANCE



Dominique FLORACK
President, Research & Development

Florance HU-AUBIGNY
R&D 3DEXPERIENCE Platform Senior VP

Philippe LAUFER
CATIA CEO

Gian Paolo BASSI
SOLIDWORKS CEO

CAPITAL MARKETS DAY

JUNE 14-15, 2018 | PARIS CAMPUS, FRANCE



3DEXPERIENCE®

New Reach with Cloud | Start-up, AEC ...

New Industry Reach with CLOUD

Brands
"User Experience" & Communities



Industries
"Solution Experience"

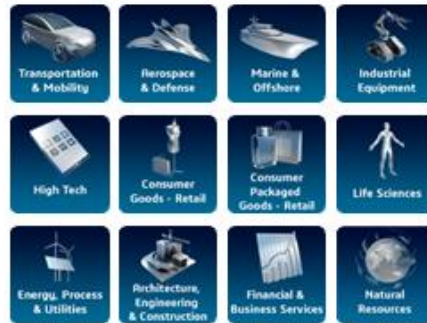

12 Geo Field Operations
"Customer Experience"



New Industry Reach with CLOUD

Reasons to Believe

Brands
"User Experience" & Communities



Industries
"Solution Experience"



12 Geo Field Operations
"Customer Experience"



1

POWER'BY
Connecting all
our existing Users

POWER'BY

SOCIAL CONNECT & COLLABORATE

3DEXPERIENCE
Social Collaboration Services

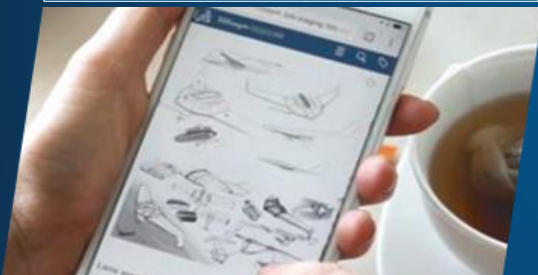

PLM CONNECT & REVEAL

3DEXPERIENCE
PLM Collaboration Services



DISCOVER & MODEL EXPERIENCES

3DEXPERIENCE Roles



Industry Innovation

Business Innovation



3DEXPERIENCE Social Collaboration Services



3DEXPERIENCE
Social Collaboration Services

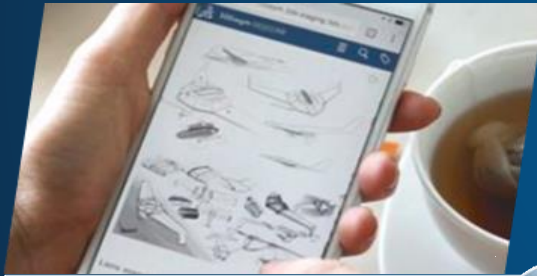

Business Innovation

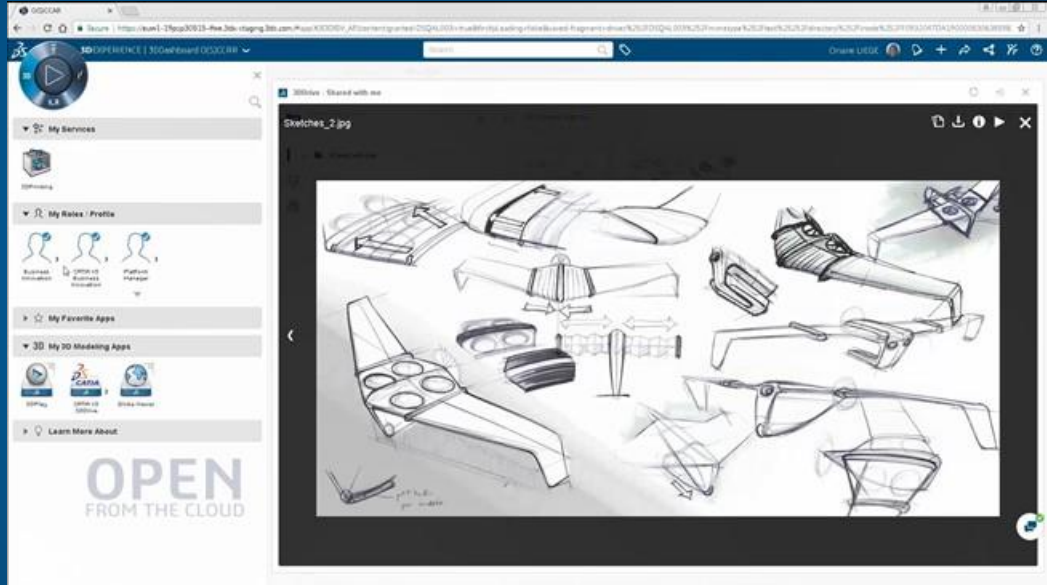

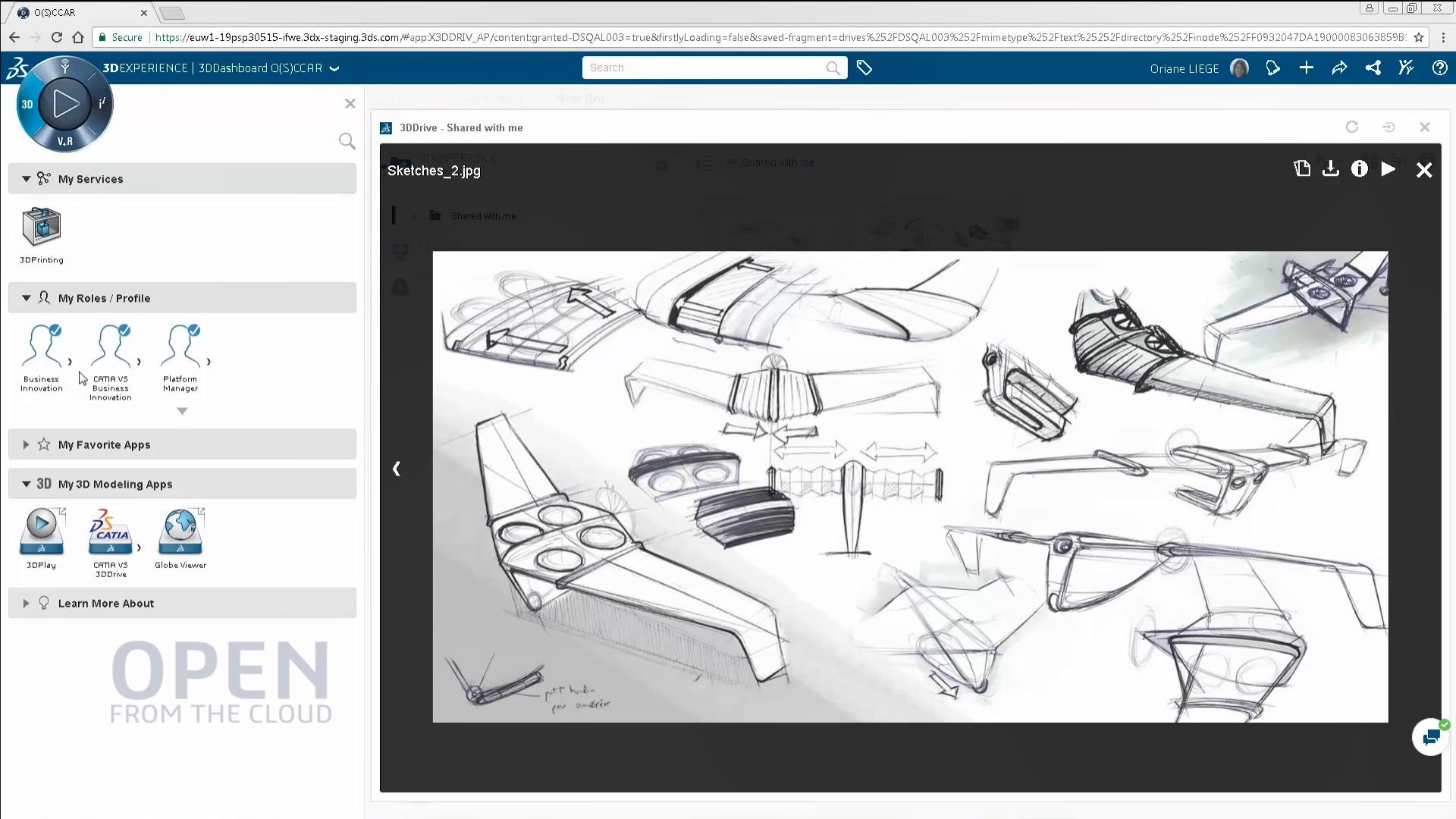

3DEXPERIENCE | 3DDashboard O(S)CCAR

Search

3D V.R

My Services



3DPrinting

My Roles / Profile

Business Innovation

CATIA V5 Business Innovation

Platform Manager

My Favorite Apps

My 3D Modeling Apps

3DPlay

CATIA V5 3DDrive

Globe Viewer

Learn More About

OPEN FROM THE CLOUD

3Drive - Shared with me

Sketches_2.jpg

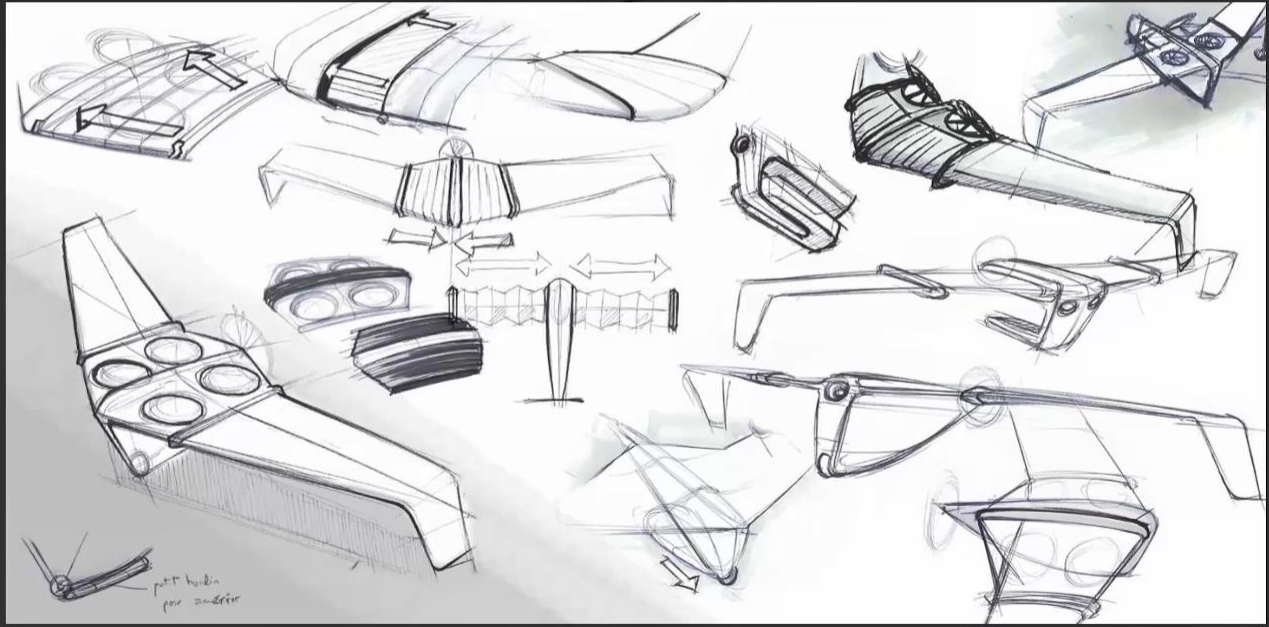

3DEXPERIENCE PLM Collaboration Services



3DEXPERIENCE
PLM Collaboration Services

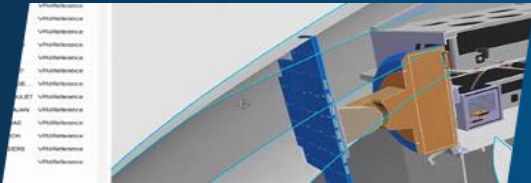

Industry Innovation

Business Innovation



The screenshot displays the 3DEXPERIENCE PLM Collaboration Services interface. On the left, there is a navigation pane with sections for 'Last Modified By', 'Organization', 'Responsible', 'Creation Date', 'Modification Date', 'Collaborative Policy', 'Maturity', 'Reservation', 'Subtype', 'Type', 'Unit of Measure', and 'Collaborative Space'. The main area is divided into two panes. The left pane shows a 'Product Structure Explorer' for 'DISMONTAGE1' with a table of items:

Title	Revision	Responsible	Modification Date
GLD-PartsCyls	A.1	Aurélien TRAUVERT	3/10/2017, 10:13:31
GLD-Cabrer	A.1	Lola MALAPLATAS	3/10/2017, 10:41:42
GLD-Cabrer	A.1	Fabrice BORGERS	3/10/2017, 10:28:07
GLD-Cabrer	A.1	Fabrice BORGERS	3/10/2017, 10:28:07
Reservatio	A.1	Fabrice BORGERS	3/10/2017, 10:28:07
GLD-BelleA	A.1	Fabrice BORGERS	3/10/2017, 10:28:07
GLD-Poste	A.1	Fabrice BORGERS	3/10/2017, 10:28:07
AngerCabre	A.1	Fabrice BORGERS	3/10/2017, 10:28:07
Reauitans	A.1	Fabrice BORGERS	3/10/2017, 10:28:07
Cignotaris	A.1	Fabrice BORGERS	3/10/2017, 10:28:07
Cignotaris	A.1	Fabrice BORGERS	3/10/2017, 10:28:07
PlaqueCov	A.1	Fabrice BORGERS	3/10/2017, 10:28:07
RevelPlaque	A.1	Fabrice BORGERS	3/10/2017, 10:28:07
RevelPlaque	A.1	Fabrice BORGERS	3/10/2017, 10:28:07
Supportage	A.1	Fabrice BORGERS	3/10/2017, 10:28:07
NewSticker	A.1	Fabrice BORGERS	3/10/2017, 10:28:07
NewSticker	A.1	Fabrice BORGERS	3/10/2017, 10:28:07
GLD-Echappes	A.1	Lola MALAPLATAS	3/10/2017, 10:41:42
GLD-Echappes	A.1	Fabrice BORGERS	3/10/2017, 10:28:07

The right pane shows a 3D model of a motorcycle with various components highlighted in different colors (orange, blue, yellow, pink). The interface includes a search bar, navigation icons, and a status bar at the bottom.

6WTags

- Last Modified By: 1
- Organization: 1
- Responsible: 1
 - Maxime AUREJAC: 238
 - Loris MALAPTIAS: 45
 - fredericartur: 20
 - Fabrice BORGERS: 15
 - Pierre LEROUX: 7
 - Aurelien TRAVERT: 2
 - Isabelle BONNER: 1
- Creation Date: 1
- Modification Date: 1
- Collaborative Policy: 1
- Maturity: 1
- Reservation: 1
- Subtype: 3
- Type: 2
- Unit of Measure: 1
- Collaborative Space: 1

ENOVIA - Product Structure Explore - DSMotorbikeA1

	Title	Revision	Responsible	Modification Date
👁	🔍	📦 DSMotorbikeA1	A.1 Aurelien TRAVERT	7/7/2017, 10:13:31 ...
👁	🔍	📦 GLD-PartieCycl	A.1 Loris MALAPTIAS	7/7/2017, 10:45:42 ...
👁	🔍	📦 GLD-Cadret	A.1 Fabrice BORGERS	7/7/2017, 10:28:07 ...
👁	🔍	📦 GLD-Gardel	A.1 Fabrice BORGERS	7/7/2017, 10:28:07 ...
👁	🔍	📦 ReservoirDC	A.1 Fabrice BORGERS	7/7/2017, 10:28:07 ...
👁	🔍	📦 GLD-SelleA	A.1 Fabrice BORGERS	7/7/2017, 10:28:07 ...
👁	🔍	📦 GLD-Positio	A.1 Fabrice BORGERS	7/7/2017, 10:28:07 ...
👁	🔍	📦 AngleCadre	A.1 Fabrice BORGERS	7/7/2017, 10:28:07 ...
👁	🔍	📦 Bavette-arri	A.1 Fabrice BORGERS	7/7/2017, 10:28:07 ...
👁	🔍	📦 ClignotantA	A.1 Fabrice BORGERS	7/7/2017, 10:28:07 ...
👁	🔍	📦 ClignotantA	A.1 Fabrice BORGERS	7/7/2017, 10:28:07 ...
👁	🔍	📦 PlaqueDQN	A.1 Fabrice BORGERS	7/7/2017, 10:28:07 ...
👁	🔍	📦 RivetPlaque	A.1 Fabrice BORGERS	7/7/2017, 10:28:07 ...
👁	🔍	📦 RivetPlaque	A.1 Fabrice BORGERS	7/7/2017, 10:28:07 ...
👁	🔍	📦 Supportdepl	A.1 Fabrice BORGERS	7/7/2017, 10:28:07 ...
👁	🔍	📦 NewSticker_	A.1 Fabrice BORGERS	7/7/2017, 10:28:07 ...
👁	🔍	📦 NewSelleDC	A.1 Fabrice BORGERS	7/7/2017, 10:28:07 ...
👁	🔍	📦 GLD-Echappem	A.1 Loris MALAPTIAS	7/7/2017, 10:45:42 ...
👁	🔍	📦 GLD-Ech	A.1 Pierre LEROUX	7/7/2017, 10:25:30 ...

ENOVIA - 3D Navigate - DSMotorbikeA1

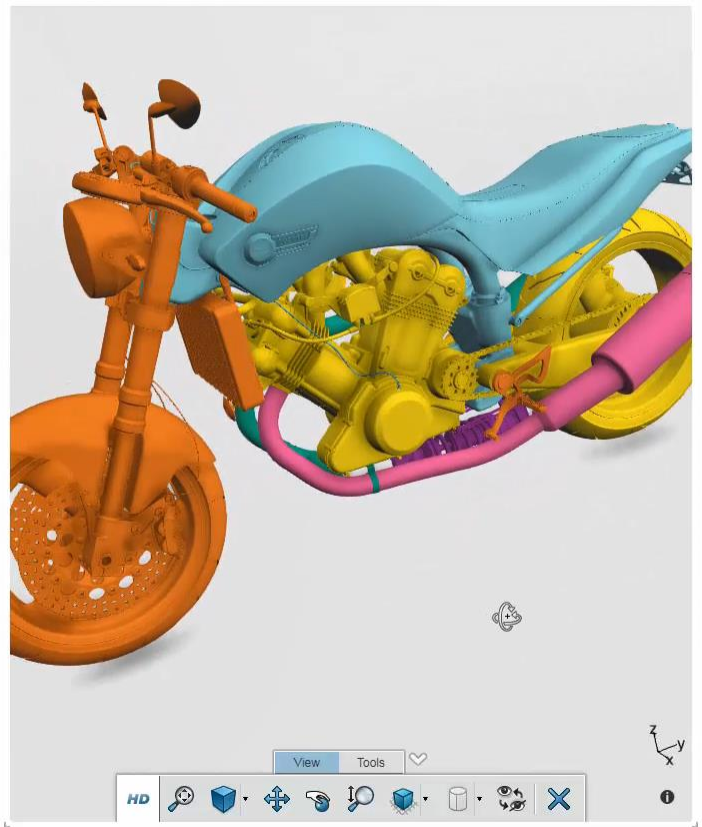

View Tools

View Tools

3DEXPERIENCE PLM Collaboration Services



3DEXPERIENCE
PLM Collaboration Services



Industry Innovation

Business Innovation

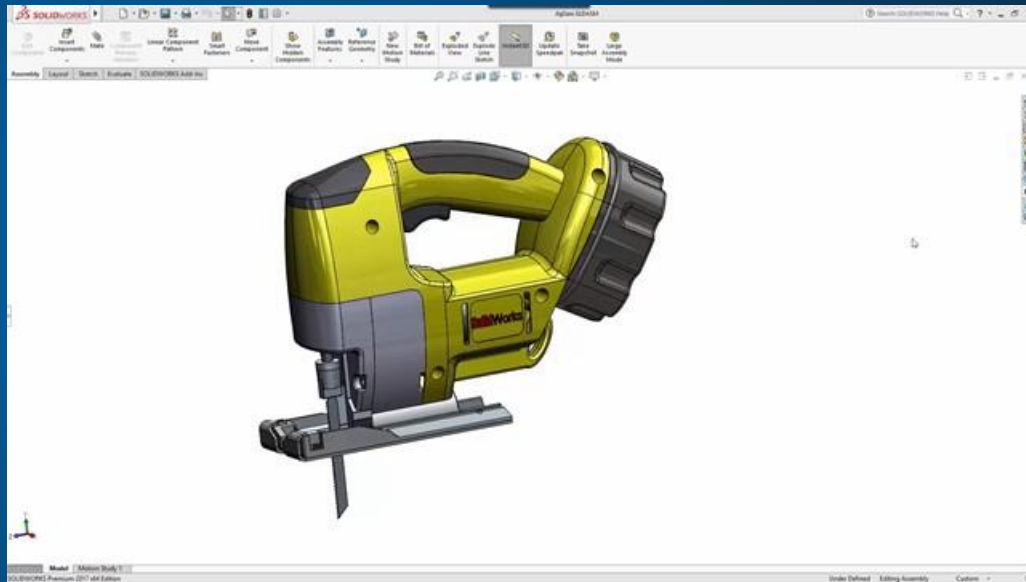

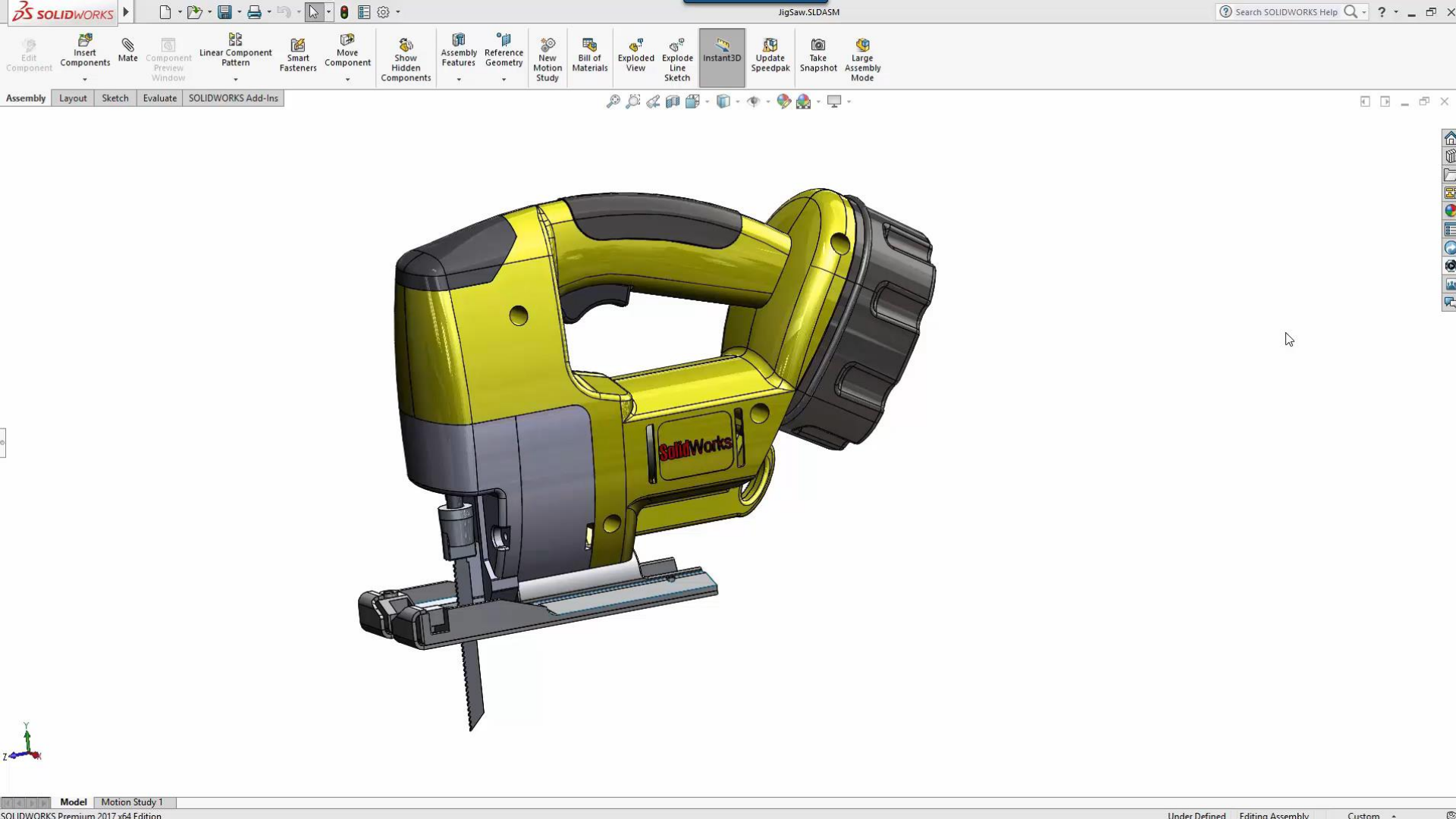

New Industry Reach with CLOUD

Reasons to Believe

Brands
"User Experience" & Communities



Industries
"Solution Experience"



12 Geo Field Operations
"Customer Experience"



2 Industry Renaissance
- AEC
- Mobility

AEC | The Renaissance is on the Cloud

- **Connecting AEC to City & territory Management**
- **Industry Processes addressing the 3DEXPERIENCE Twin Lifecycle**
- **Empowering the AEC Value Network**



Connecting AEC to City & territory Management

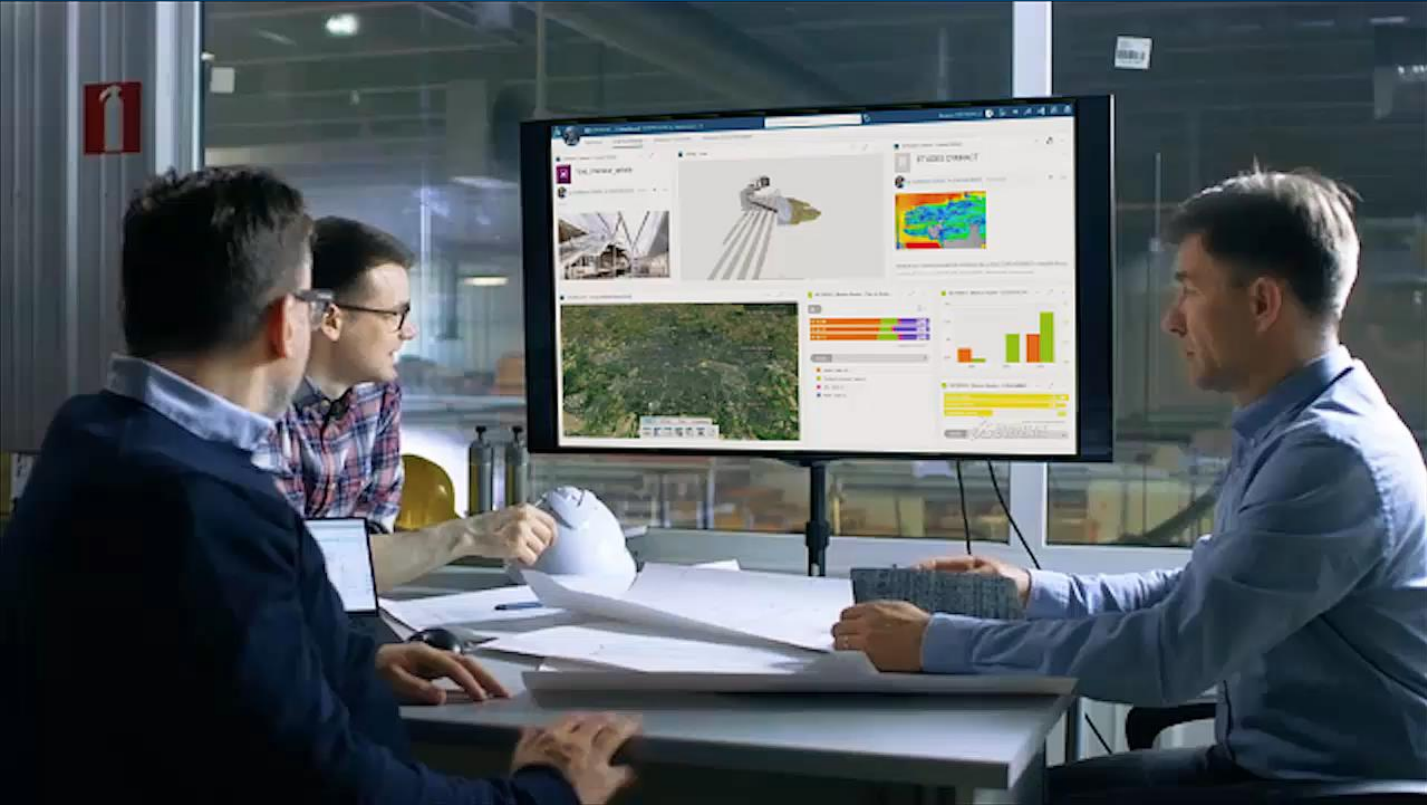

Industry Processes addressing the 3DEXPERIENCE Twin Lifecycle

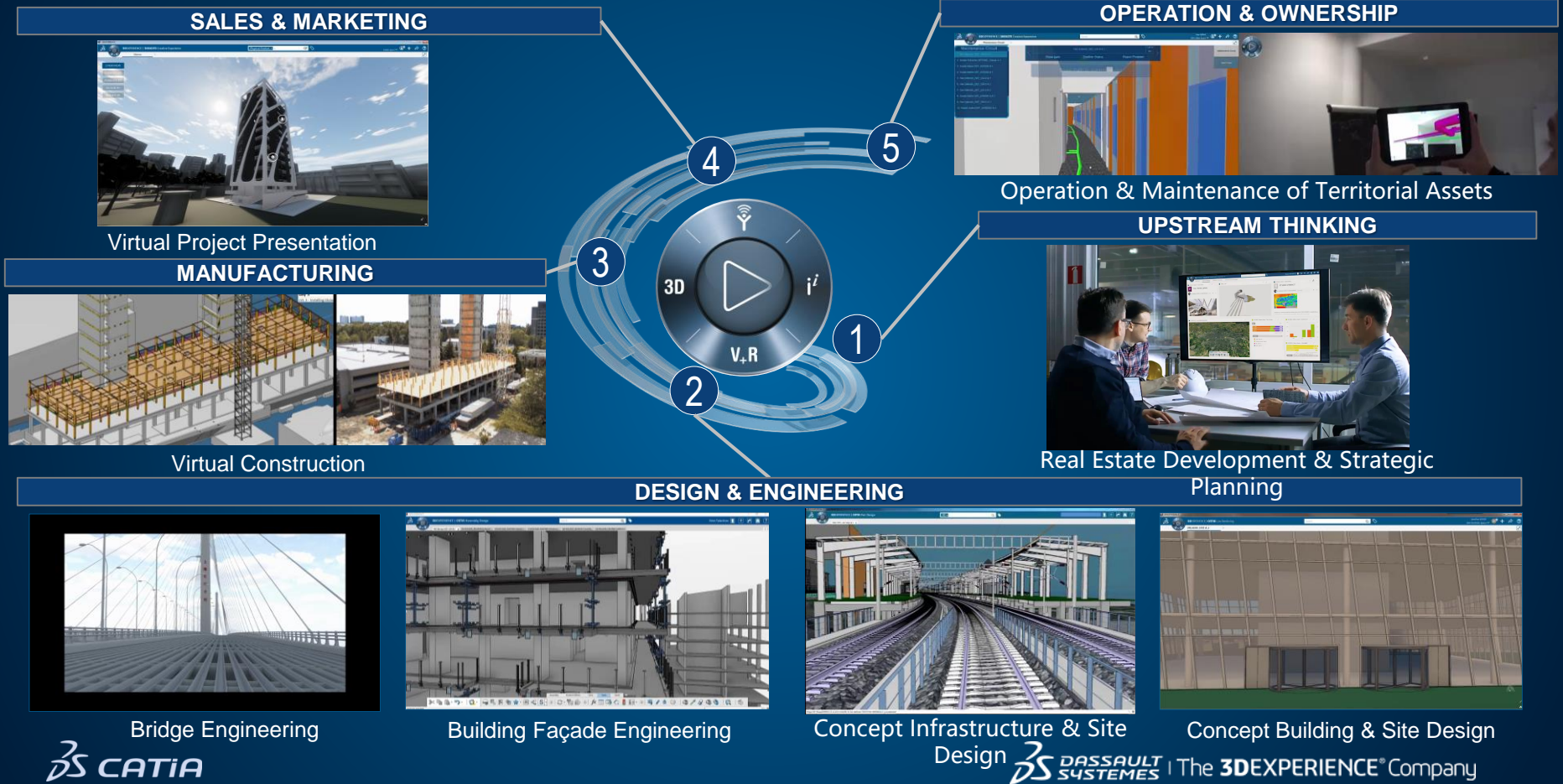

Empowering the AEC Value Networks



Empowering the AEC Value Networks | Reason to believe

Remote
On site

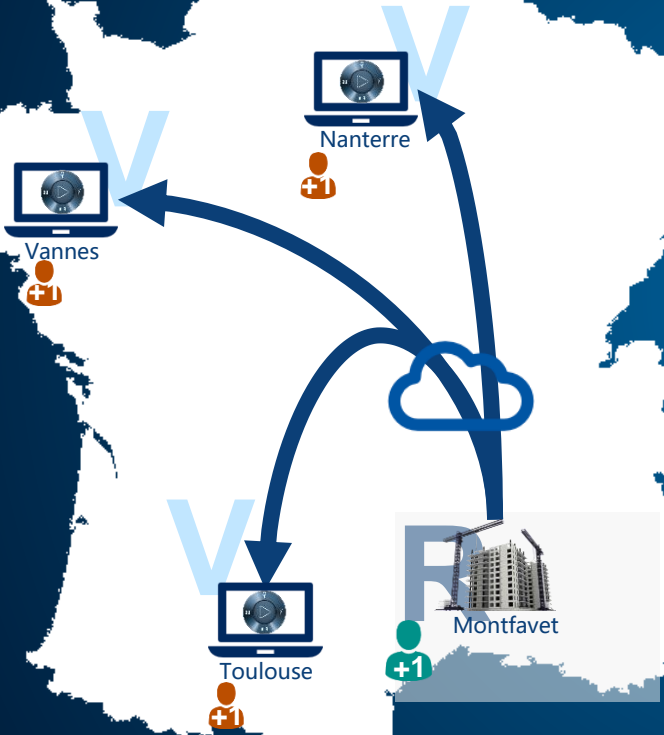

3DEXPERIENCE Twin
at the Heart of AEC

« We gained 20%
cost reduction
during the
construction
Phase »
P. Guéhéneux

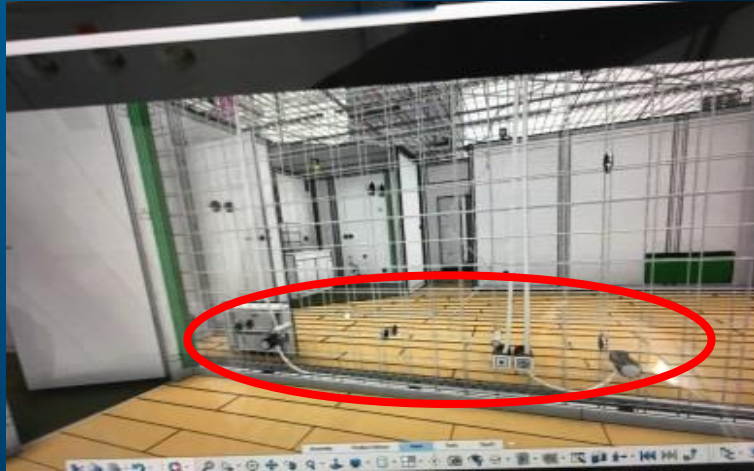
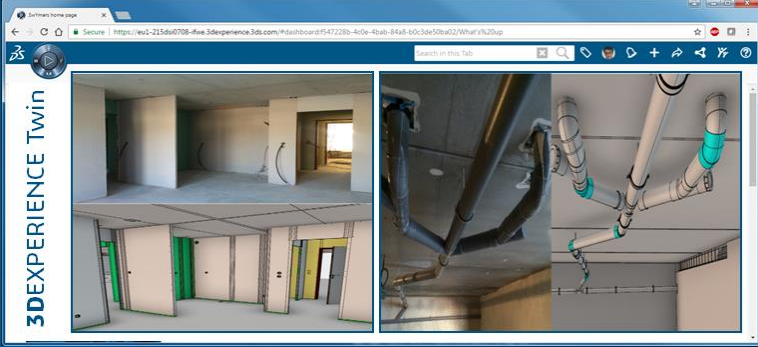

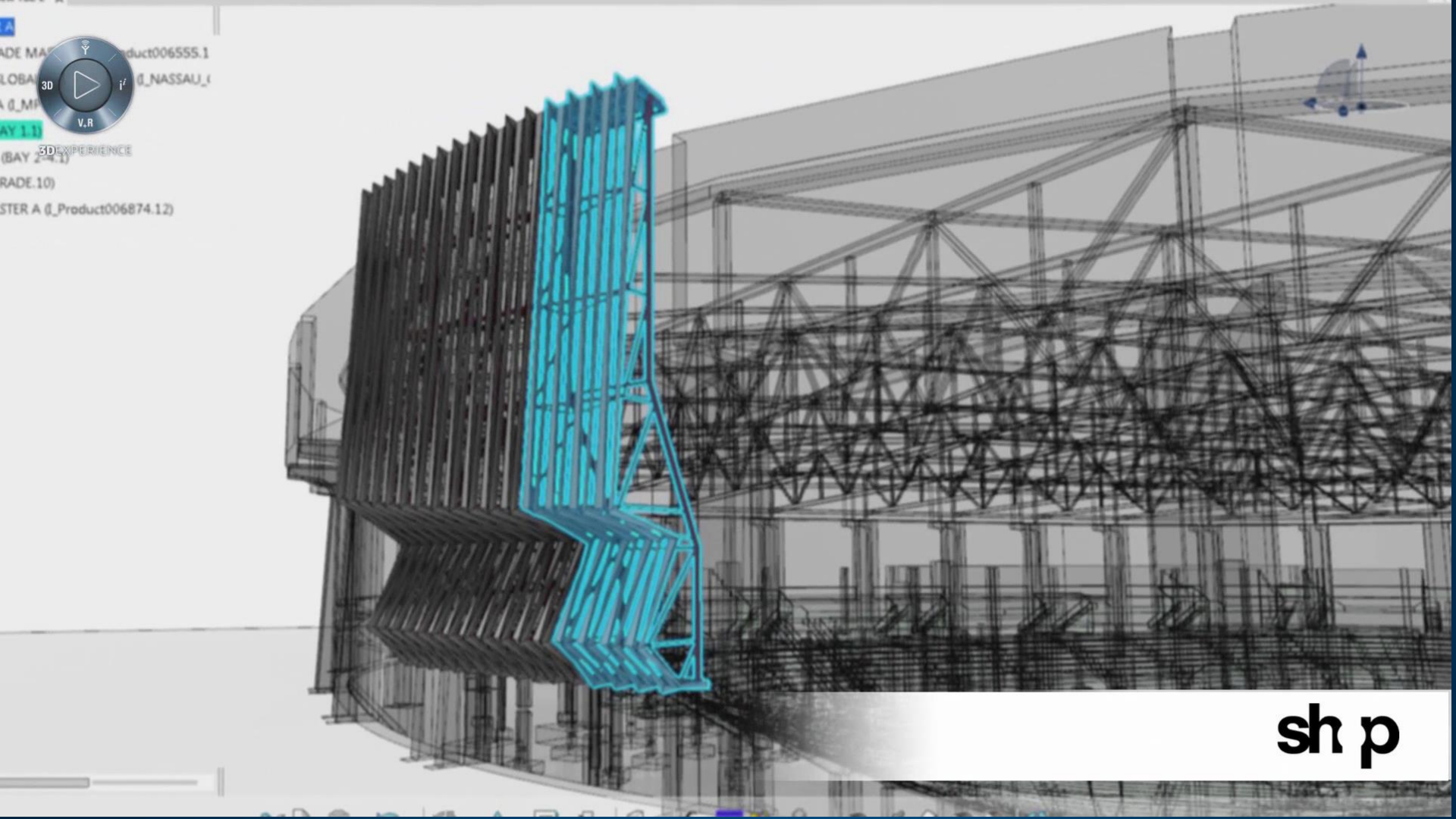

Product006555.1
LOBAL
A (_M
AY 1.1
3D EXPERIENCE
(BAY 2-4.1)
RADE.10)
STER A (_Product006874.12)

sh p

Mobility | The Shakers are on the Cloud

- **Industry Processes covering the entire Mobility Experience Lifecycle**
- **3DEXPERIENCE, your Innovation Hub**
- Reason to believe : eMobility
- **3DEXPERIENCE, source of Know How**



Lifecycle

Reason to believe : Design/Engineering Portfolio for Transportation & Mobility

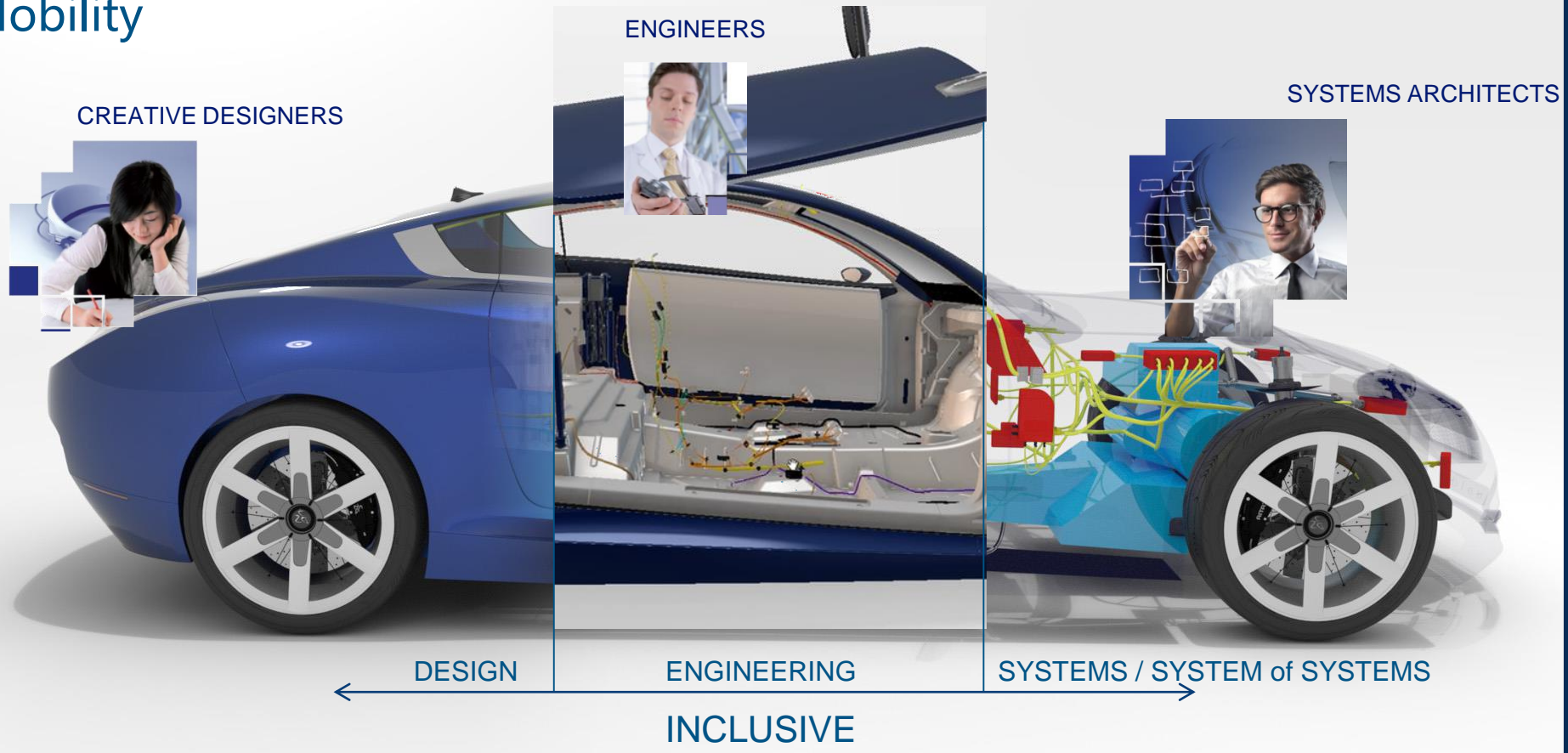

Lifecycle

Reason to believe : Design/Engineering Portfolio for Transportation &

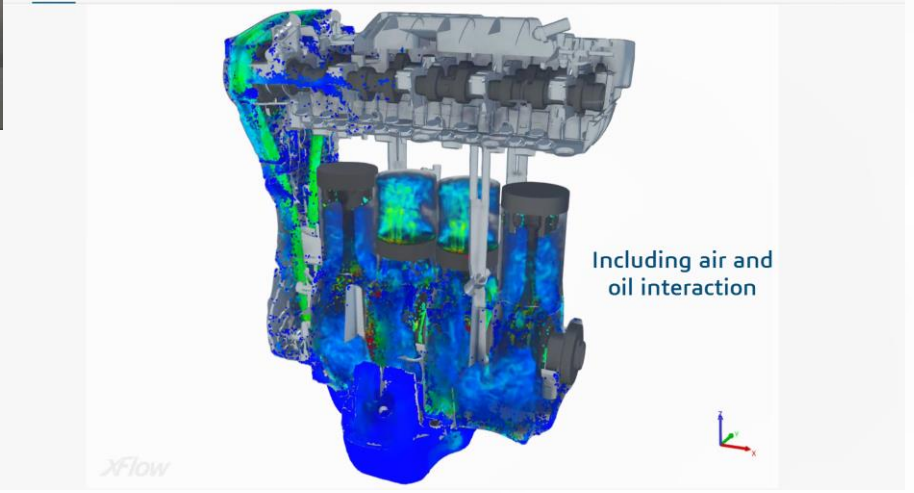
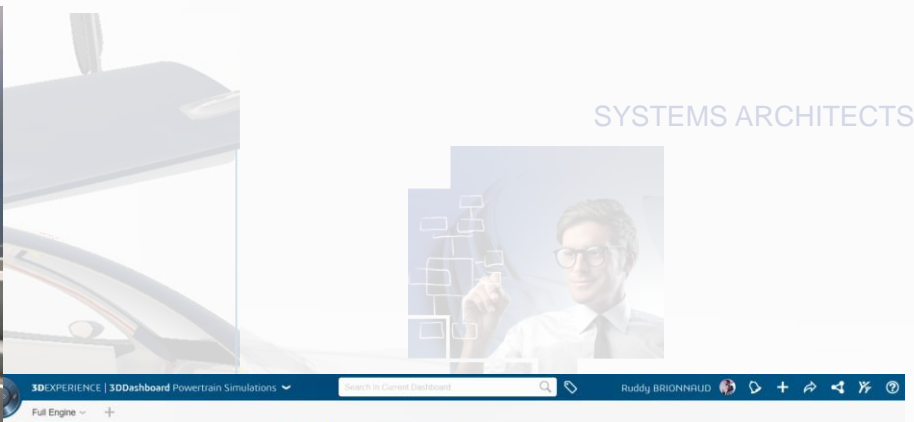
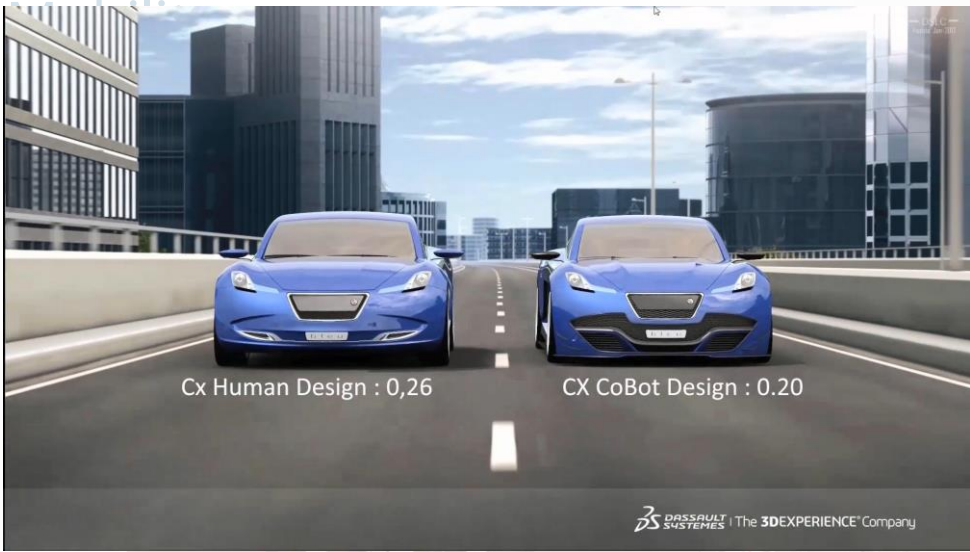

3DEXPERIENCE, your Innovation Hub

Reason to believe | CATIA Roles for eMobility

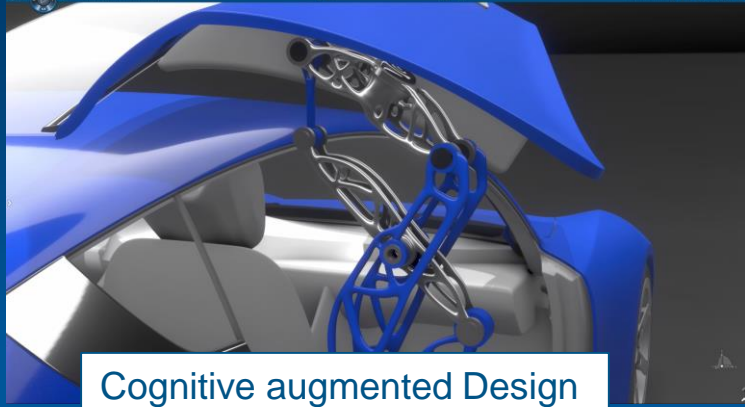

Cognitive augmented Design

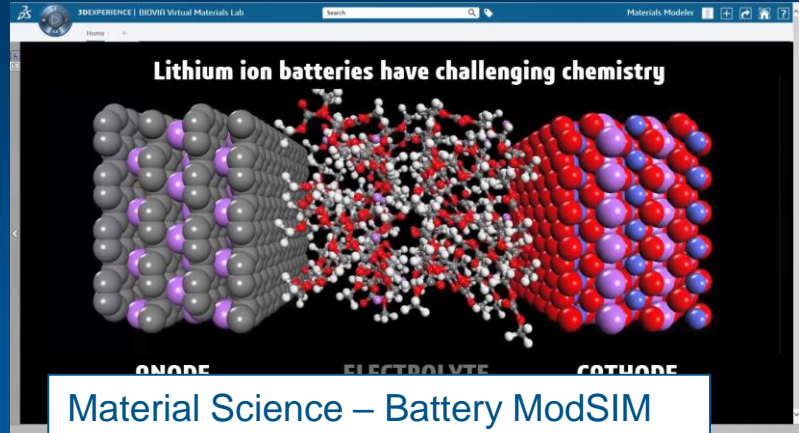

Material Science – Battery ModSIM



Cyber Systems



New Reality

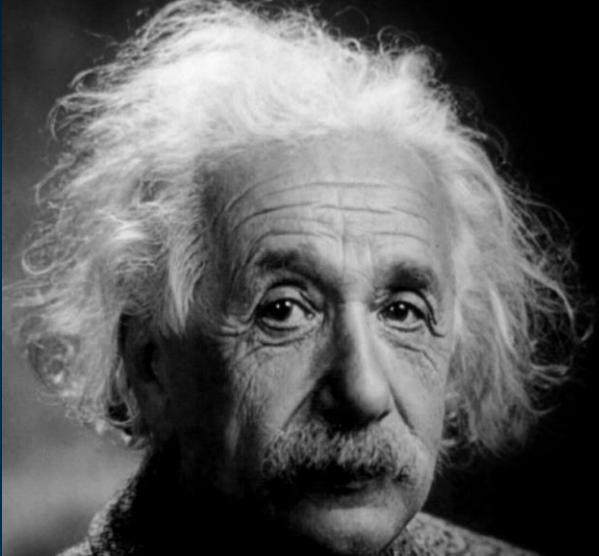

The only source of knowledge
is experience.

Albert Einstein

3DEXPERIENCE is the only
source of Know-How

Bernard Charlès



3DEXPERIENCE, source of Know How

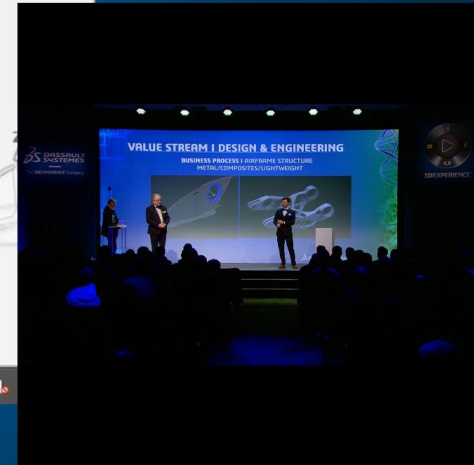
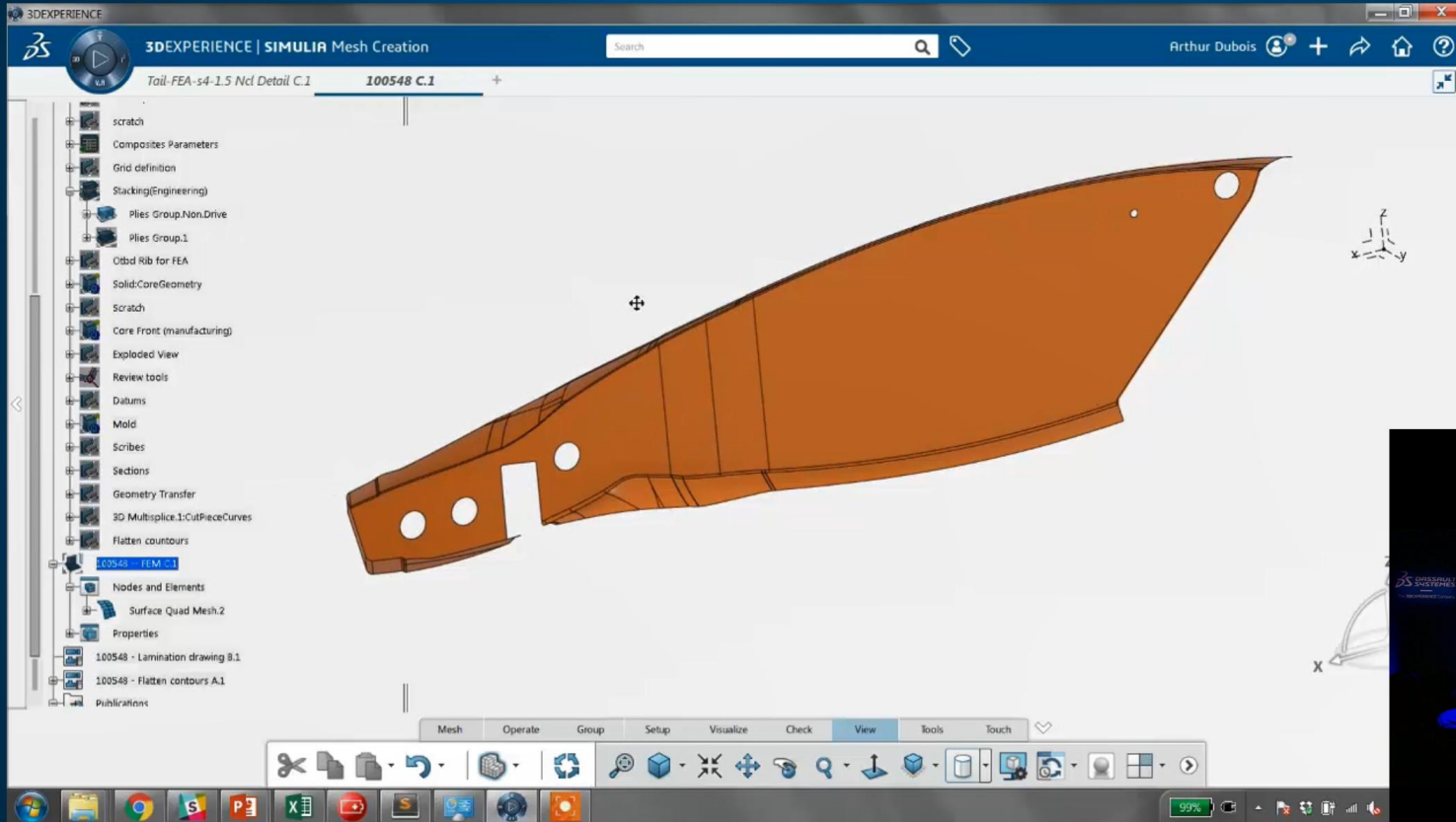

3DEXPERIENCE, source of Know How

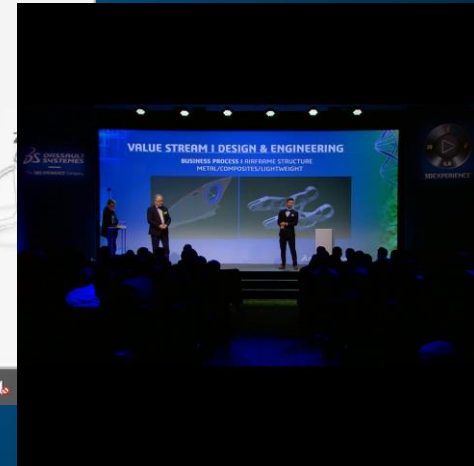
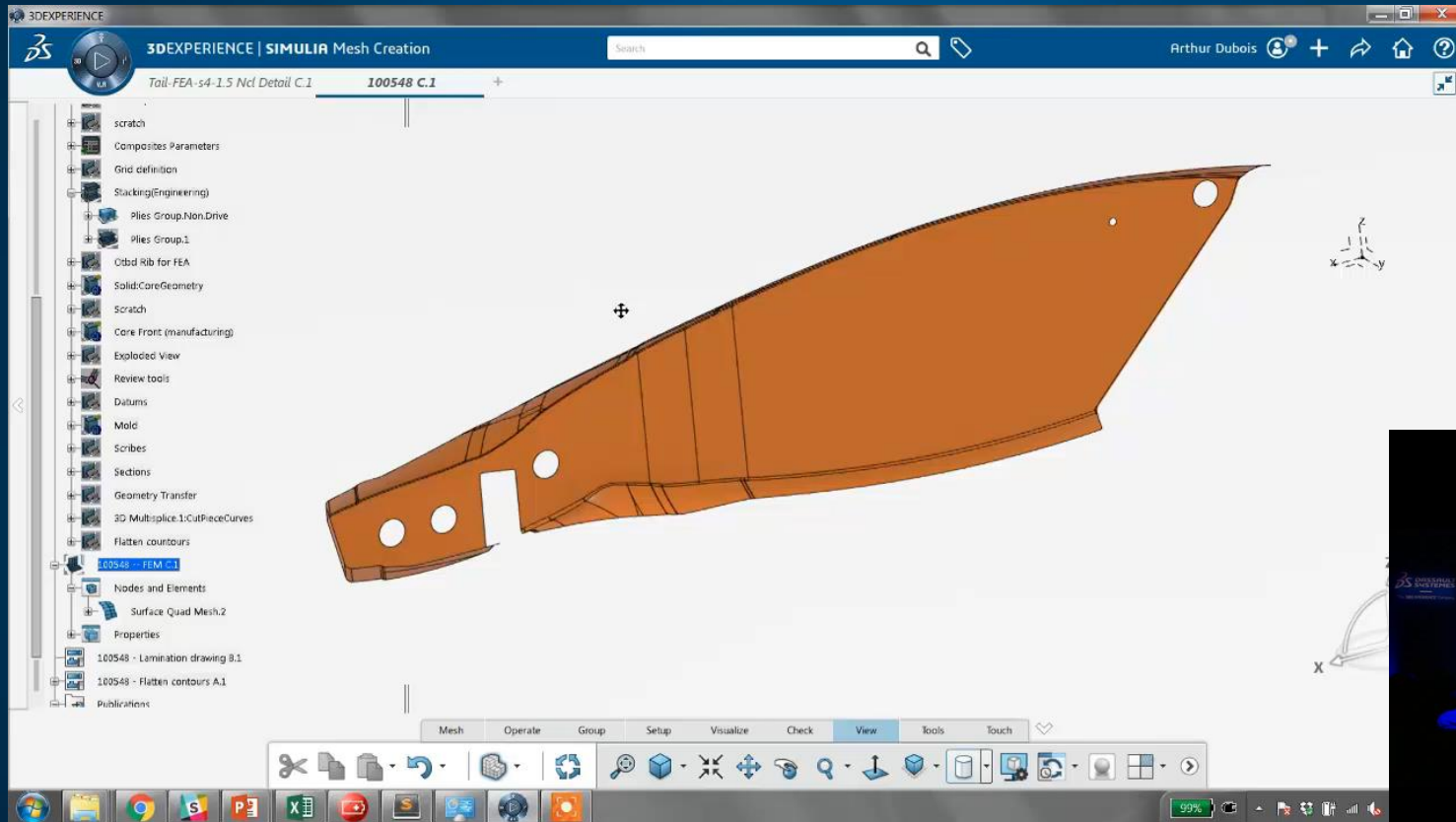

3DEXPERIENCE | eMobility Adopters

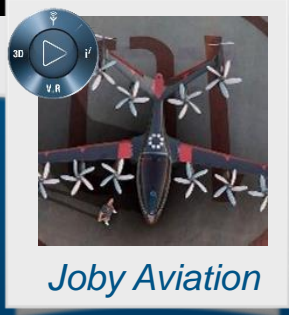
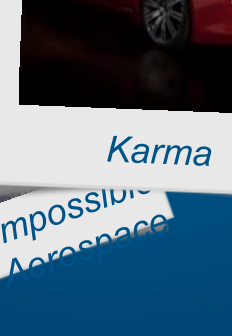
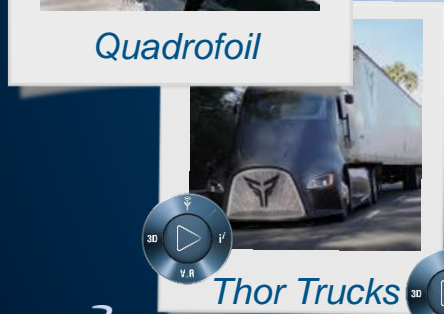
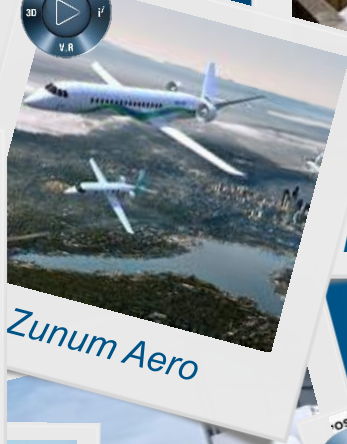
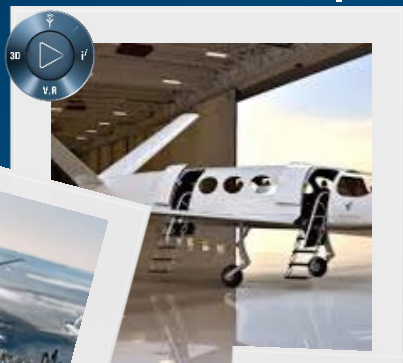



3DEXPERIENCE



JOBY



New Industry Reach with CLOUD

Reasons to Believe

Brands
"User Experience" & Communities



Industries
"Solution Experience"



12 Geo Field Operations
"Customer Experience"



3

A new Portfolio
for our SWKS Users
in the PC Channel

3DEXPERIENCE for SOLIDWORKS

SOLIDWORKS WORLD 2018



1. 3DEXPERIENCE Social Collaborative Services
2. SOLIDWORKS 3DEXPERIENCE PLM Services
3. SOLIDWORKS Product Designer
4. SOLIDWORKS xDesign
5. 3DEXPERIENCE Marketplace | Make

POWER' BY 3DEXPERIENCE Social Collaborative Services

- ▶ 3DSWYM
- ▶ 6W Tags
- ▶ 3DDashboards
- ▶ 3DDrive
- ▶ 3DPlay

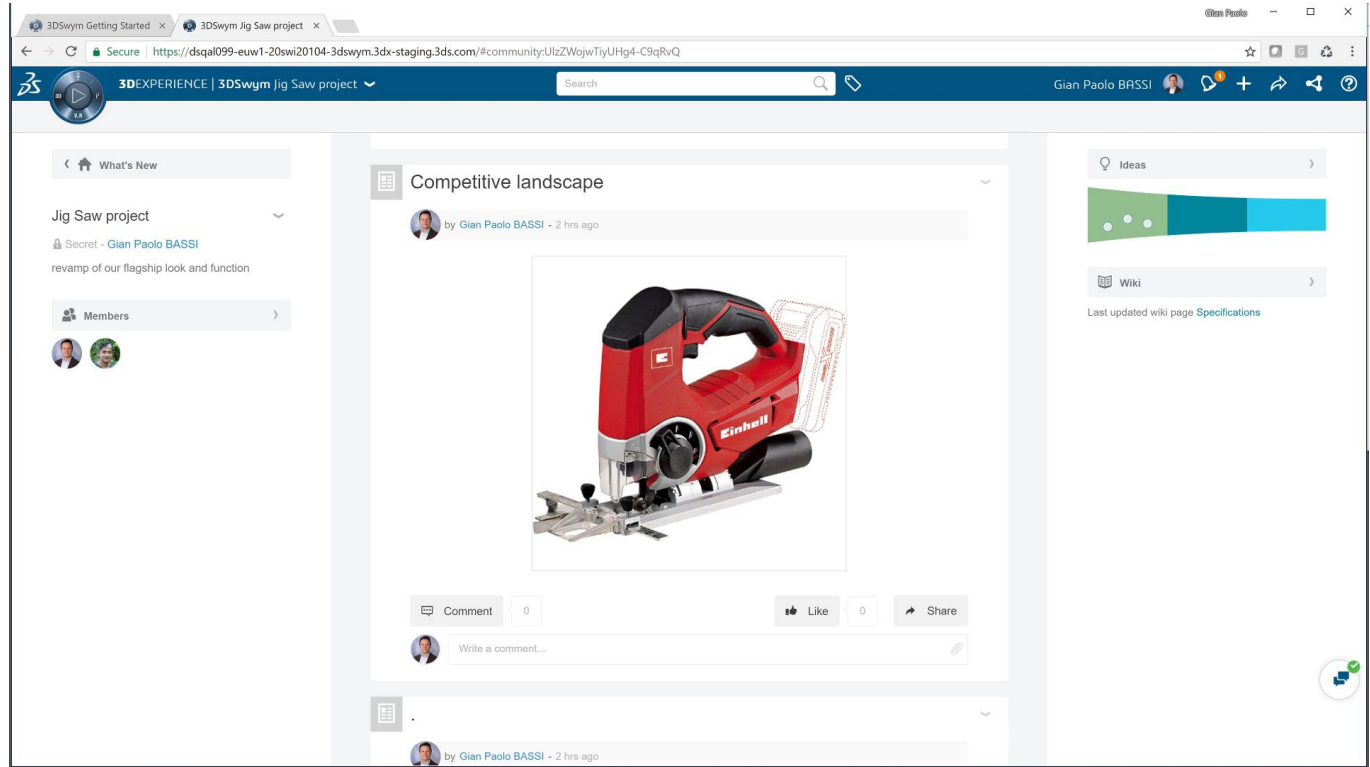

POWER' BY 3DEXPERIENCE PLM Collaborative Services

- ▶ PLM in the cloud
- ▶ Ready to use
- ▶ Fully scalable

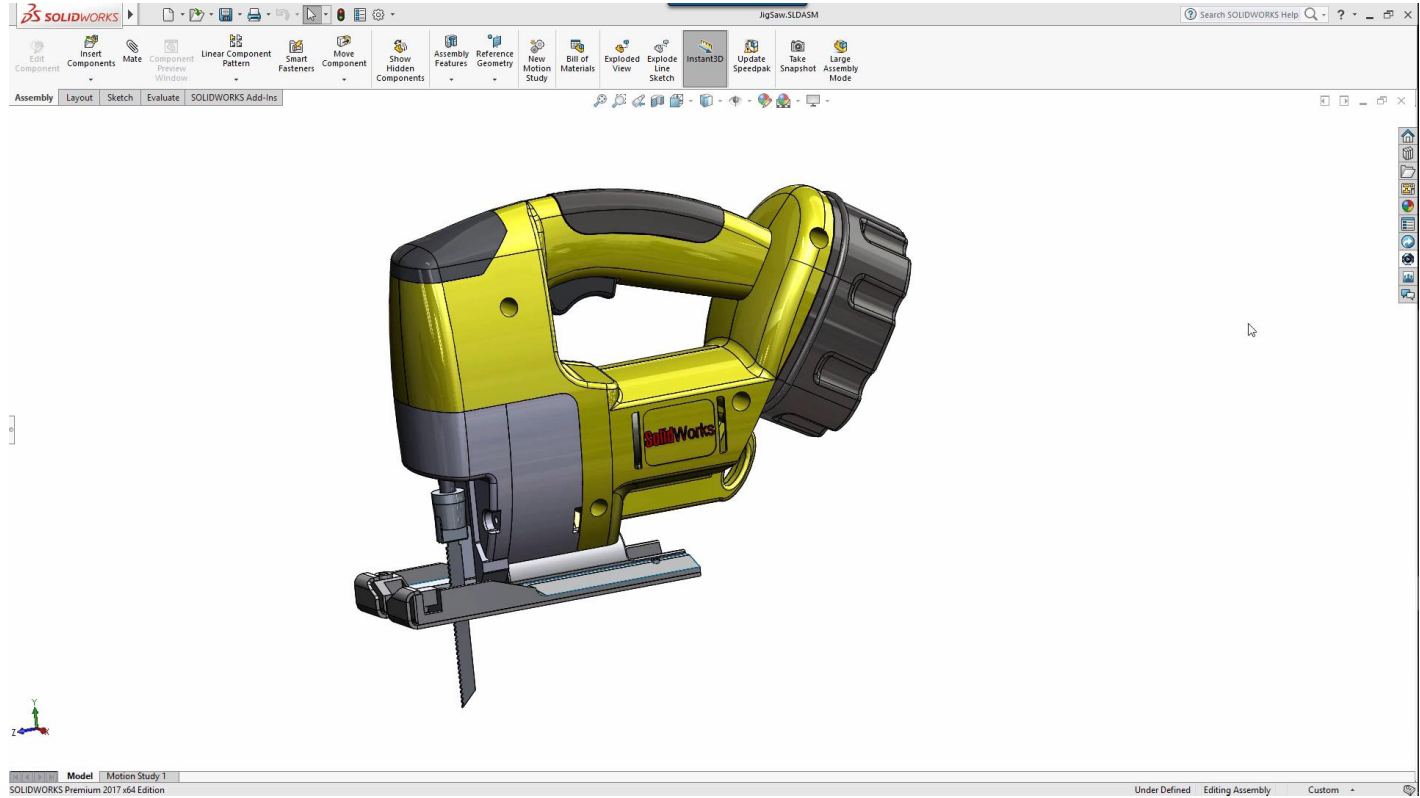

3DEXPERIENCE Platform Solutions For All SOLIDWORKS users

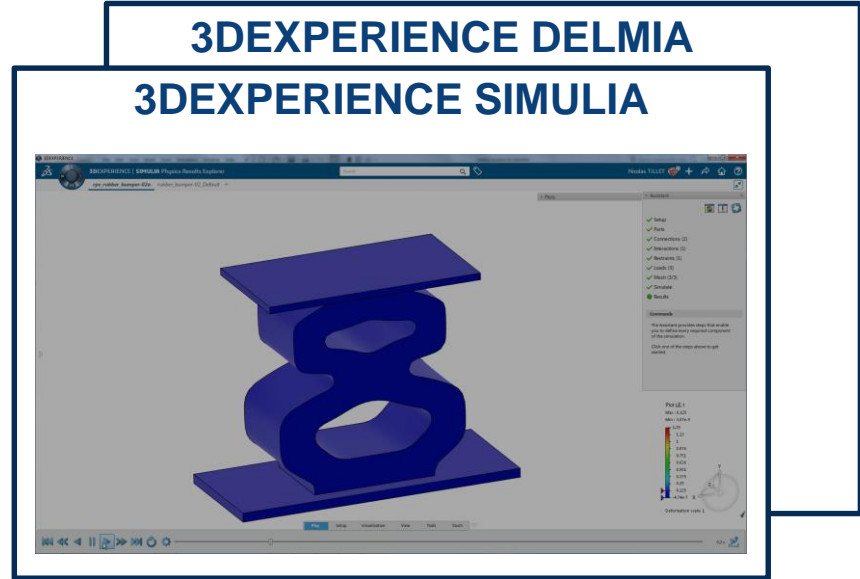
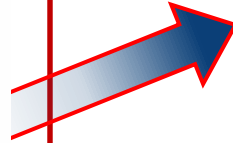

SOLIDWORKS DESKTOP **POWER'**
BY

SOLIDWORKS Product Designer

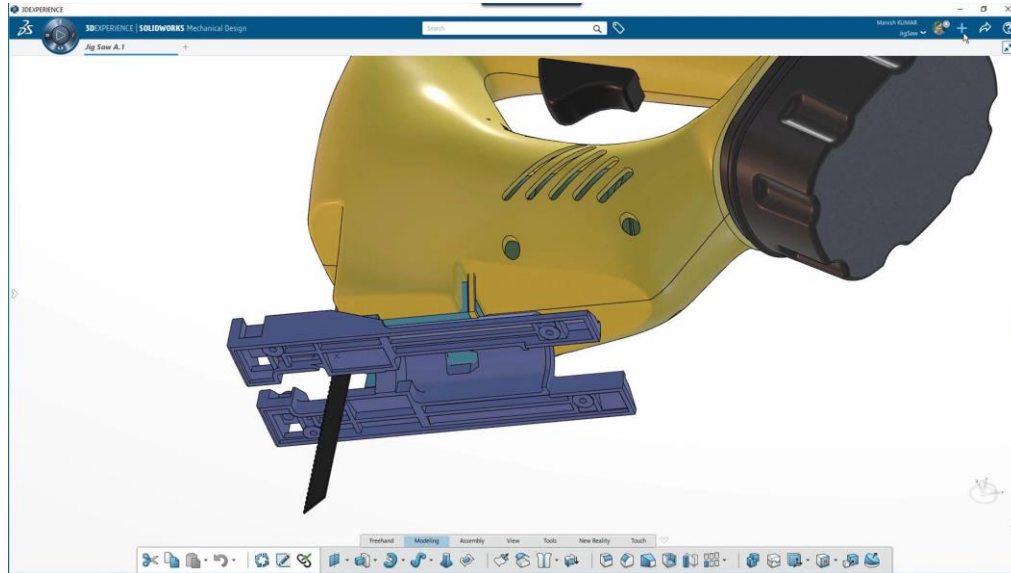

- ▶ Complete MCAD portfolio
- ▶ Natively integrated with the 3DEXPERIENCE ecosystem

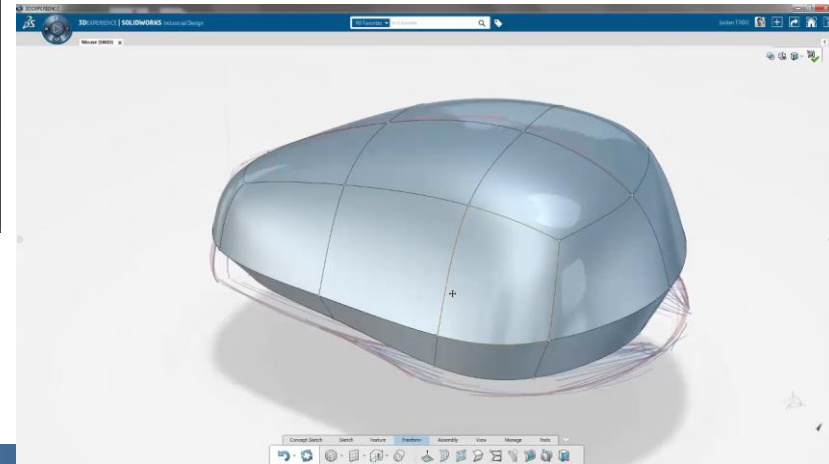

SOLIDWORKS xDesign

- ▶ Mobility
- ▶ Any device

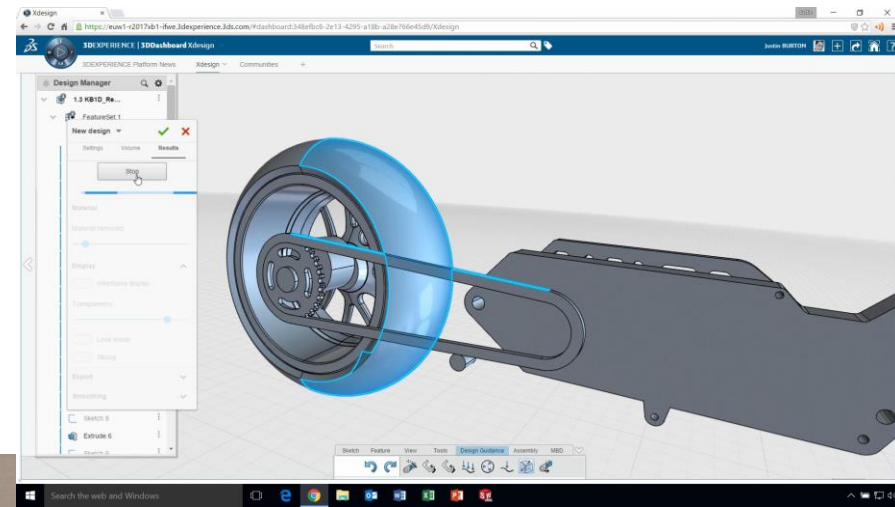

As a summary

- 1. The 3DEXPERIENCE Platform is CLOUD and the solutions are available today**
- 2. We provide world wide coverage (through 3DS Outscale and Partnerships)**
- 3. 3DEXPERIENCE platform delivers new reach**
 - in our existing customers and users base**
 - in all industries**
 - in all channels**
- 4. CLOUD delivers instant Benefits and ROI (No Deployment)**
- 5. With the CLOUD, users are always on the latest release**
- 6. CLOUD fosters new usages... and new business models**

